

Project

Item #

Quantity



GLOBE FOOD EQUIPMENT COMPANY

Automatic Slicers

3850P/3975P



3850P/3975P Automatic Slicer

Model

- 3850P - Two Speed Automatic Slicer
- 3975P - Nine Speed Automatic Slicer



Made in the U.S.A.



*Features a 13" Precise Edge™ knife,
a premium gear drive system and
Globe's exclusive EZ-Glide™ table.*

Standard Features

- 13" PreciseEdge™ hardened steel alloy knife
- Premium gear-driven knife
- Maintenance-free drive system
- Powerful 1/2 HP, 7 amp motor
- Exclusive stainless steel construction
- Built-in antimicrobial protection
- Precision gear slice thickness adjustment
- EZ-Glide™ adjustable slicing table
- Open space base design
- Knife cover interlock
- Signature knife sharpening system
- Permanently attached knife ring guard
- Full gravity feed, 45° angle
- 3 lb. stainless steel endweight
- Unique dual arm lift lever
- Touch pad controls
- Power indicator light
- No voltage release

Optional and Accessories

- Quick-Clean™ proprietary nickel-based coating (knife cover and slice table)
- Front mounted endweight assembly
- Prison package
- High moisture application package (includes stainless steel knife)
- 15" long food chute
- Aluminum food chute
- Stainless steel knife
- Low food fence (12"L x 1-3/8"H)
- High food fence (12"L x 3"H)
- 10 lb. attachable portion control scale
- Vegetable hopper
- Clear plastic slicer cover

Standard Warranty

- Two-years parts and one-year labor plus 15 years on the knife drive gears

Approved By: _____

Date: _____



GLOBE FOOD EQUIPMENT COMPANY

www.globeslicers.com

2153 Dryden Rd.
Dayton, OH 45439
Phone: 937-299-5493
Phone: 800-347-5423
Fax: 937-299-4147



Automatic Slicers

3850P/3975P

Specifications

Finish: Exclusive all stainless steel base with radiused corners improves sanitation and durability. Other stainless steel parts include the food chute, slicing table, endweight and knife cover.

Knife Motor: Powerful 1/2 HP, 7amp, 115/60/1.

Chute Motor: Two speed DC fractional horsepower 1 amp. Both motors have permanently lubricated sealed ball bearings.

Knife Drive: Cross axis helical gear drive design. This maintenance free drive design in continuously lubricated ensuring quiet operation and reliable cutting performance.

Slice Thickness: Precision dual gear design eliminates table movement during slicing. Consistently produces tissue thin slices with a maximum slice thickness of 1 1/4".

Antimicrobial Protection: Knobs and handles have antimicrobial protection built-in, which inhibits the growth of bacteria and provides superior sanitation.

Full Gravity Feed: Full 45° angle feed requires less mechanical pressure. Equipped with a 3 lb. stainless steel endweight to minimize waste and hold product. Food chute handle is ergonomically designed and the endweight swings away for storage behind the chute.

Table: EZ-Glide™ adjustable slicing table is designed to reduce surface friction, facilitating a smooth and easy slicing stroke.

Dual Arm Lift Lever: A handle activates two large wheels, lifting the front of the unit to facilitate safe and easy cleaning underneath the slicer.

Touch Pad Controls: Start/stop touch pad controls activate the knife motor.

Chute Speed: Controlled by faster/slower touch pad controls.

Knife Cover Interlock: Slicer will not operate with knife cover removed.

Knife Ring Guard: Permanently mounted knife ring guard covers the non-slicing portion of the knife protecting the operator from the knife's edge.

Top Mounted Sharpener: Metal knife sharpener is permanently mounted on the slicer. A single lever activates the stones to quickly and easily return a razor sharp cutting edge.

Hallow Ground Knife: 13" diameter special hardened steel alloy knife with stain resistant finish and sanitary hub provides increased cutting capacity, clean cuts and effortless slicing. Knife's edge has a Rockwell hardness of 60-62.

No Voltage Release: Prevents inadvertent reactivation of the slicer in the event of a power or interlock interruption.

Cutting Capacity: Width 11.6" (29.5 cm), Height 9" (22.9 cm), Diameter 7.5" (19 cm)

Power Indicator Light: A readily visible red light illuminates when the knife is rotating.

Automatic Chute: Chute travels 40/60 (model 3850P) or 20-60 (model 3975P) strokes per minute utilizing a separate DC motor with a heavy duty permanently lubricated chain and sprocket drive system. Chute can be quickly engaged or disengaged for manual operation with the auto engage lever.

Cord & Plug: Attached 7 foot flexible 3 wire cord with molded plug fits a grounded receptacle.

Dimensions:

Foot Print = 14" x 21.6"
(35.6 cm x 54.9 cm)
Overall Length = 26.2" (66.5 cm)
Overall Width = 22" (55.9 cm)
Overall Height = 25.2" (64 cm)
Freight Class: 77.5
Net Weight: 145 lbs. (67.1 kg)
Shipping Weight: 172 lbs. (79.4 kg)
Shipping Dimensions:
28"W x 25"D x 34"H
(71.1 cm x 63.5 cm x 86.4 cm)

Factory Installed Options:

Quick-Clean™ Quick-Clean™ proprietary nickel-based coating (knife cover and slicing table)
FMEW Front mounted endweight
PRISON MEATROOM Prison package High moisture application package
LONGCHUTE ALUM 15" long food chute Aluminum food chute
SSK Stainless steel knife

Factory Installed Options:

1326 High fence (12" x 3")
1047 Low fence (12" x 1 3/8")
873-SET PS13 3" extension legs 10 lb. attachable portion control scale
699-BAS SC-GLOBE Vegetable hopper Clear plastic slicer cover

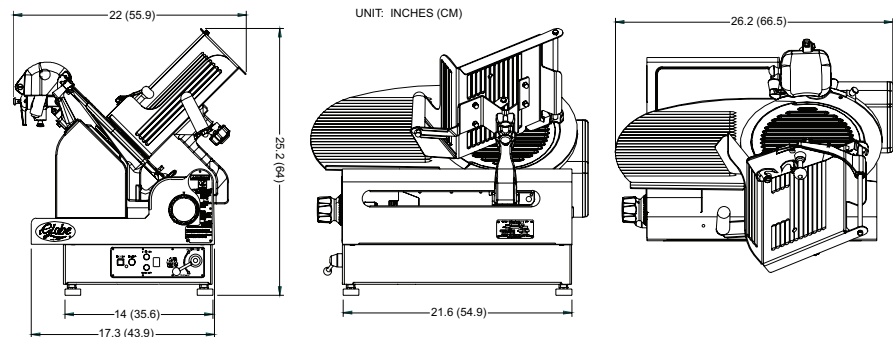

GLOBE FOOD EQUIPMENT COMPANY

www.globeslicers.com

2153 Dryden Rd.
Dayton, OH 45439
Phone: 937-299-5493
Phone: 800-347-5423
Fax: 937-299-4147

Printed in U.S.A. 11-2009

Specifications are subject to change without notice.